



Drive Solutions for the Global Mining Industry

metals

cranes

mining

testing

oil & gas

renewable
energy

power
generation

cement

About TMEIC

A Global network

TMEIC is built on the combined and proud heritage of Toshiba and Mitsubishi-Electric in the industrial automation, control and drive systems business. TMEIC's global business employs more than 2,200 employees, with sales exceeding U.S. \$2.4 billion, and specializes in Metals, Oil & Gas, Material Handling, Utilities, Cement, Mining, Paper and other industrial markets.

TMEIC Corporation, headquartered in Roanoke, Virginia, designs, develops and engineers advanced automation and variable frequency drive systems.

The factory for the World's factories

TMEIC delivers high quality advanced systems and products to factories worldwide, while serving as a global solutions partner to contribute to the growth of our customers.

Customer Service

At TMEIC, our focus is on the customer, working to provide superior products and excellent service, delivering customer success every project, every time.

Variable Frequency Drives in the Mining Industry

Every step of the way, from the mine to the finished product, variable frequency drives (VFDs) are used to smoothly start large motors and continuously adjust the speed as required by the machine or process. Induction

and synchronous motors driving excavators, conveyors, mills, fans, and pumps use VFDs to provide high power and speed control, as well as generate significant associated energy and maintenance savings.

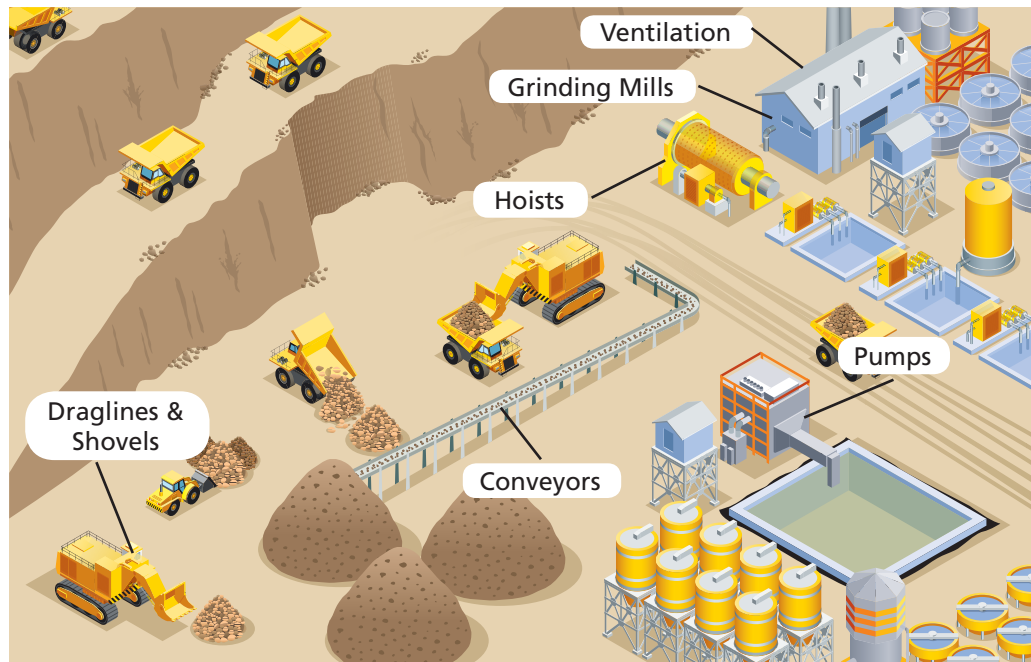

- Large draglines and shovels require drives to provide high power to all the motors running the machine with controlled torque and speed.
- Long conveyors require drives for starting and running, in particular to provide controlled starting torque to avoid belt slip, and the ability to adjust speed to match processing needs.
- The TMdrive®-10/30/50/70 family of drives and TMEIC motors are also well-suited for mine hoist applications.
- Drives are useful in soft starting large mill motors. Motor life is extended by eliminating inrush currents. Low currents at start also benefit the power delivery system by reducing voltage dips.

Why Use Electrical Variable Frequency Drives?

Here are some of the reasons to use VFDs in the mining industry:



Increased Reliability

Pages 4, 5, 9

Variable frequency motor-drive systems are more reliable than traditional mechanical approaches such as using throttling valves, gears, or turbines to control speed and flow. Because electric drives have no moving parts, they provide very high reliability.



Good Control over Earth Moving Machines

Page 9

Responsive speed and position control of large machines with mechanical functions such as hoist, swing, and drag, require powerful variable frequency drives. Long conveyors also require accurate torque and speed control provided by VFDs.



Soft Starting One or Multiple Mill Motors, and Improved Power Factor

Pages 4, 5

When electric drives soft start large motors, starting inrush current with associated heating and thermal stress is eliminated. This removes limitations on motor frequency of starts, reduces insulation damage, and provides extended motor life. With synchronization logic, one drive can soft start multiple motors. Finally, large variable frequency drives can improve overall system power factor.



Significantly Less Maintenance

Page 15

Mine equipment demands high system availability. Electric variable frequency drive systems have no moving parts, and are very low maintenance. This is in sharp contrast to speed control devices such as pumps, valves, gears, and turbines that do require extensive periodic maintenance with associated downtime.

Why TMEIC Drives Make Sense



Engineering Expertise

Pages 11

TMEIC drive and motor application engineers bring an average of 25 years of practical industry experience to your application. After analyzing your system requirements, they can recommend the most cost effective solution and design the complete drive system for you.



Choose TMEIC, a Global Supplier

Page 14

TMEIC manufactures, sells and services drive systems worldwide, supported by engineering and service offices in North & South America, Europe, Asia, Japan and Australia.



We've got you covered! A Complete Family of Drives

Pages 15

Our family of low and medium voltage (LV and MV) drives covers all your needs from 450 hp up to 12,000 hp (335 kW to 8,950 kW) and beyond, with a wide output voltage range up to 11 kV, and a line of dc drives and motor generator controls to meet your requirements.



Configuration Software

Page 15

The world-class software configuration tool is used on all TMEIC drives. Live block diagrams and tune-up wizards streamline commissioning and maintenance activities.

Application 1. Grinding Mill Systems

Grinding mills are crucial to mineral processing operations. As lower quality ore bodies are tapped, the tonnage processed per ounce of salable material will increase. This degradation in ore quality requires more power in the mill circuit, meaning larger motors and drives. Synchronous, squirrel cage induction, and wound rotor motors may be a good choice depending on the needs of the individual project. Variable frequency drives (VFD) can be paired with the motors for added benefits.

For Induction motors, a VFD will compensate for poor power factor resulting from the motor operation. TMEIC's medium voltage drive family operates near unity power factor over a wide speed range. Multi-pulse front ends also eliminate concerns over harmonic content by performing better than IEEE 519 requirements.

Modern regenerative drives like TMEIC's TMdrive-70e2 medium voltage drive are capable of operating a motor while simultaneously providing leading VARs back to the power system to counteract the lagging power factor caused by other inductive loads. This drive makes it possible to have variable speed operation and the leading power factor benefit from a synchronous motor.

Speed control is possible for wound rotor motors using TMEIC's Slip Power Recovery Drive (SPR). Instead of wasting power through a liquid rheostat or resistor bank, the SPR drive returns that power to the line. The SPR drive also enables super-synchronous operation. Another added benefit is from the built-in redundancy enabling fixed speed operation in the unlikely event of a drive fault. These benefits are all on top of the added process control that variable speed operation allows.



Benefits of Variable Speed Drive and Synchronous Motor

Power factor correction. By supplying leading VARs, regenerative drives can help correct poor plant power factor. This compensation can eliminate the need for expensive capacitor banks.

Speed control for added process efficiency. As ore bodies change, a variable speed mill will enable operators to adjust with changing conditions to maximize efficiency

Smooth starting on a weak power system. VFDs can eliminate voltage dip and other power quality problems associated with starting large motors across the line. VFDs also provide full torque immediately for difficult loaded starting conditions

Motor coordination and load sharing for dual pinion systems. Large dual pinion mills need coordinated operation between the two driving motors to maximize gear and mill life.

TMEIC's experience group of application engineers will help you design the optimal system by helping you evaluate costs and benefits of any motor and drive system, tailored to your specific site's needs.

Application 1 (continued). Multiplexing a Drive to Start and Control Three Large Mill Motors

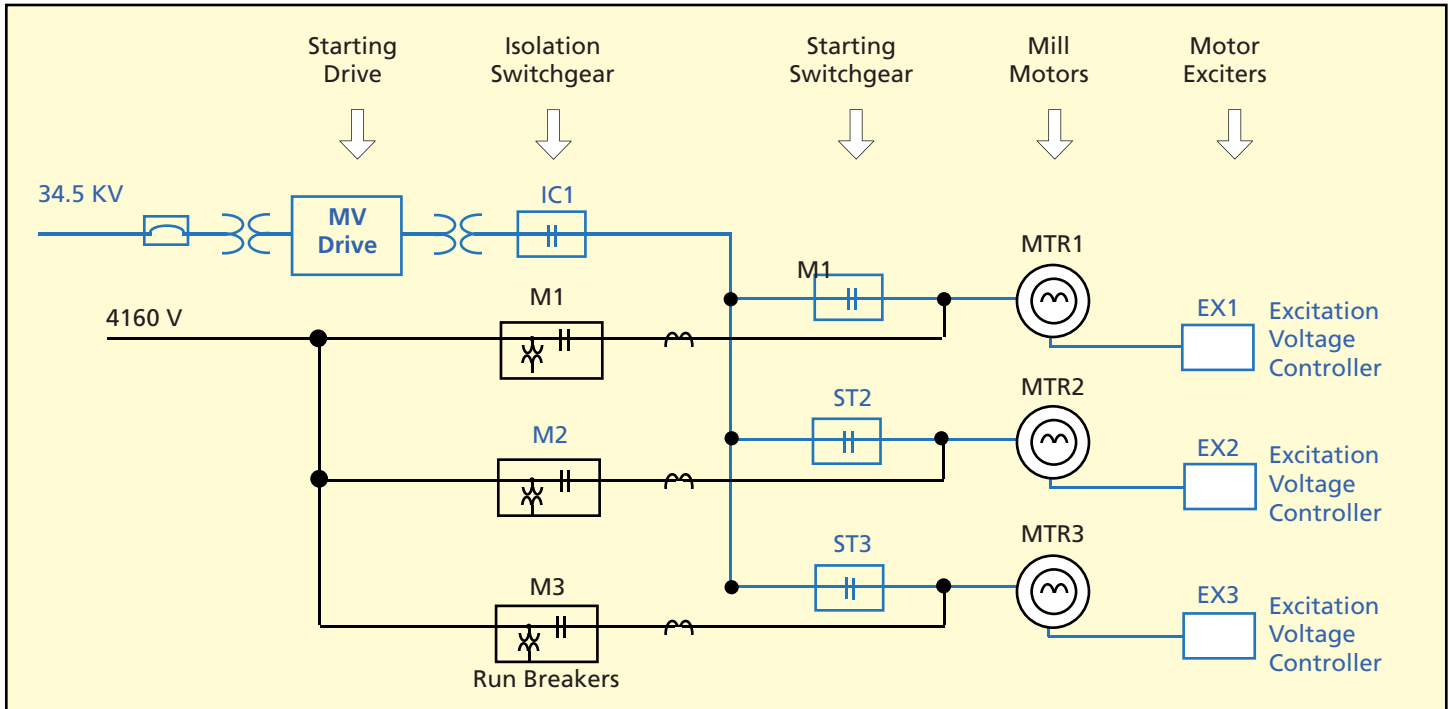

One-line for multi-motor start by a VFD

Shared Drive Starting System is Cost Effective

All three grinding mills are driven by synchronous motors of identical ratings. One drive can start any of the three motors in any desired sequence as shown by the blue lines in the figure above. Once the synchronous motor is started, the drive synchronizes the motor with the supply to operate directly across the line.

As soon as the first mill motor is started and bypassed to the line, the drive is available to start the second mill. The same process is repeated to make the drive available for starting the third mill.

All three mills can operate directly across the line, or one can remain connected to the drive for variable frequency operation if required. Because of the sharing, this system minimizes the customer's capital cost.

Synchronous Transfer

The drive is responsible for the actual phase and voltage matching for the final transfer of the motor to utility operation. This transition is coordinated to within a few milliseconds that eliminate damaging torques or loss of motor synchronization.

Soft Starting

The drive keeps the motor starting currents below full load amps at all times. Starting the motor across the line without the drive, the starting inrush current is six times full current. Using the drive, motor stress is significantly reduced and motor life is extended.

Application 2. Slip Power Recovery Drive System for Grinding Mill

This ore processing facility in Papua New Guinea can process up to 4.7 million tons of ore per year. The variable frequency drive application is a dual-pinion SAG mill driven by two 5,000 kW wound rotor induction motors (WRIM). Two TMdrive-10SPRs control motor speed by recovering rotor current and returning the power to the utility supply. Configured in a twin motor arrangement, the motors share load in the tandem mill.

The Customer Need

Reliability, power dependency and logistics were a challenge for this project. Limited access to the mine's remote location required power recovery and stellar reliability in its operations.

Grinding Mill Design Challenges

Motors: Two, 5,000 kW Wound Rotor Induction Motors

- Twin motor application
- One motor provides speed control, one provides torque control
- Motors share the load in the tandem mill

Drive Challenges: The drives must be:

- Reliable for continuous service
- Energy efficient and Low maintenance

Drive Solution: TMdrive-10 SPR drive for each motor

- Two, 690 VAC TMdrive-10SPR line-ups with 1800 frame converters and inverters
- Drive power level is only 750 kW

Control Challenges: The system required:

- Speed range 85% - 110% rated speed
- Variable speed operation of motors

Control Solution: 1800 frame Toshiba V Series PLCs

Power Challenges:

Power Solution: Slip Power Recovery.

- TMdrive-10SPR Slip Power Recovery drives
- Continuously recovers an estimated 770 kW



SAG Mill and Motor

Benefits of Slip Power Recovery Drive



Very reliable system. Standard low voltage drive hardware, with a proven track record for performance and reliability.

- High reliability is suitable for the remote location
- Reduction in maintenance and down time
- Inherent fault tolerance - a failure of the SPR drive will not prevent the motor's operation



Energy efficient

- The SPR drive offers high overall system efficiency, thus saving energy and lowering operating costs
- Can perform additional VAR compensation utilizing extra capacity in the converters



Latest Drive Technology

- Modern drive control provides the latest drive communications, operating accuracy, and diagnostics
- Standard TMEiC low voltage drive hardware is applied for use as a wound rotor motor drive
- The TMdrive-10 drive hardware requires no modifications in the slip power recovery drive application



Precise control of wound rotor motor while conserving energy

- Soft starts the mill motors
- Drives control motor torque (rotor current) directly; motors do not have to increase slip (slow down) to increase torque, providing faster control response than Liquid Rheostat Control
- Slip power is recovered and fed back to power system, saving energy

Application 2 (continued). Slip Power Recovery Drive System for Grinding Mill

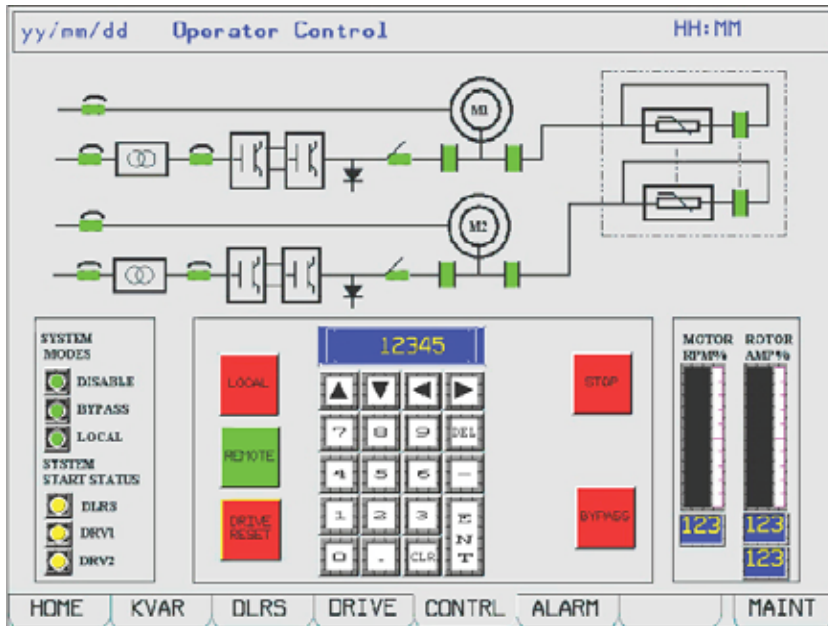

SAG Mill Operator's Screen (HMI)

The SAG mill operator's control screen shown illustrates the two wound rotor motors M1 and M2. Liquid rheostat starters on the right are switched in before starting and switched out when the motor reaches SPR regulating speed.

Recovered slip power from the rotor flows to the left through the slip power recovery drives and out through the transformers to the supply.

Motor speeds up to 110% of synchronous speed are possible, if torque and horse power limitations are observed.

Electric power savings using Slip Power Recovery are considerable. An example calculation is shown on the next page.

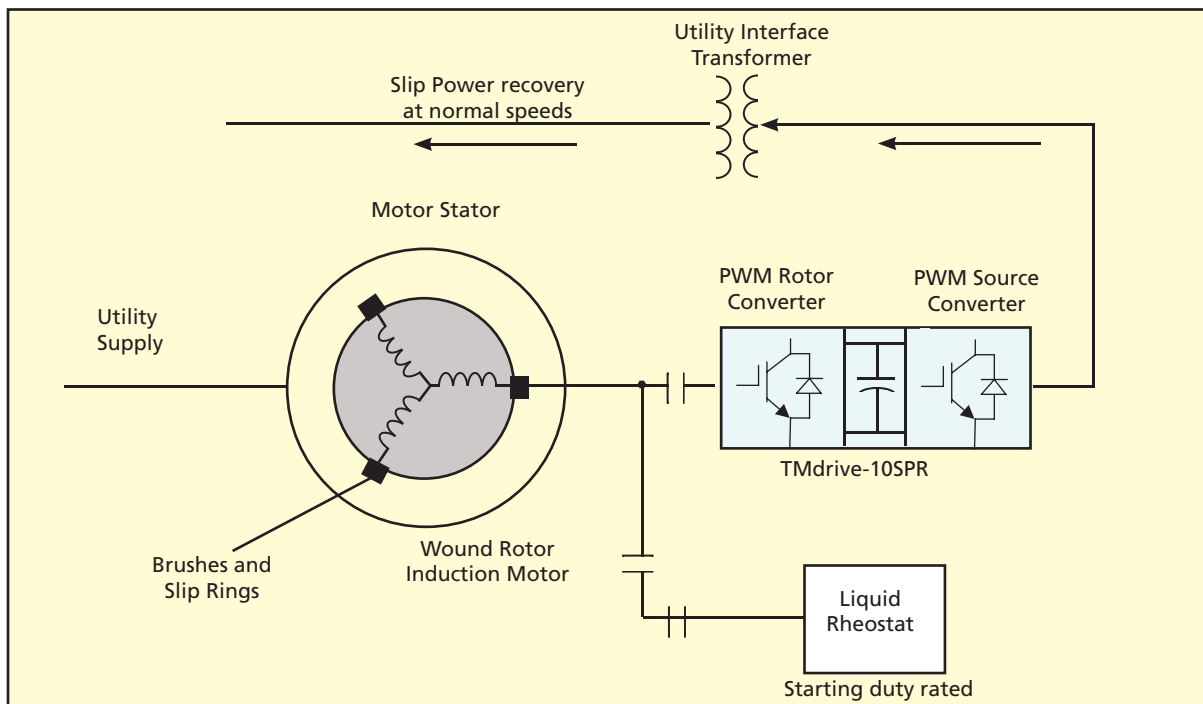

One-line of SPR operation

SPR Operation

The TMdrive-10SPR takes power out of the rotor to reduce the motor speed. At reduced speeds, power flows out of the rotor through the SPR to the transformer and back into the supply, instead of being dissipated in the rheostat.

The SPR provides the highest efficiency VFD configuration because only a fraction of the motor power goes through the drive, in this case only 750 kW, out of 5,000 kW motor power. During startup the rheostat is connected to the rotor and the SPR is disconnected. Once up to minimum speed, the SPR drive is connected and the rheostat disconnected. The motor speed is then controlled by the SPR.

Calculated Recovered Energy Savings

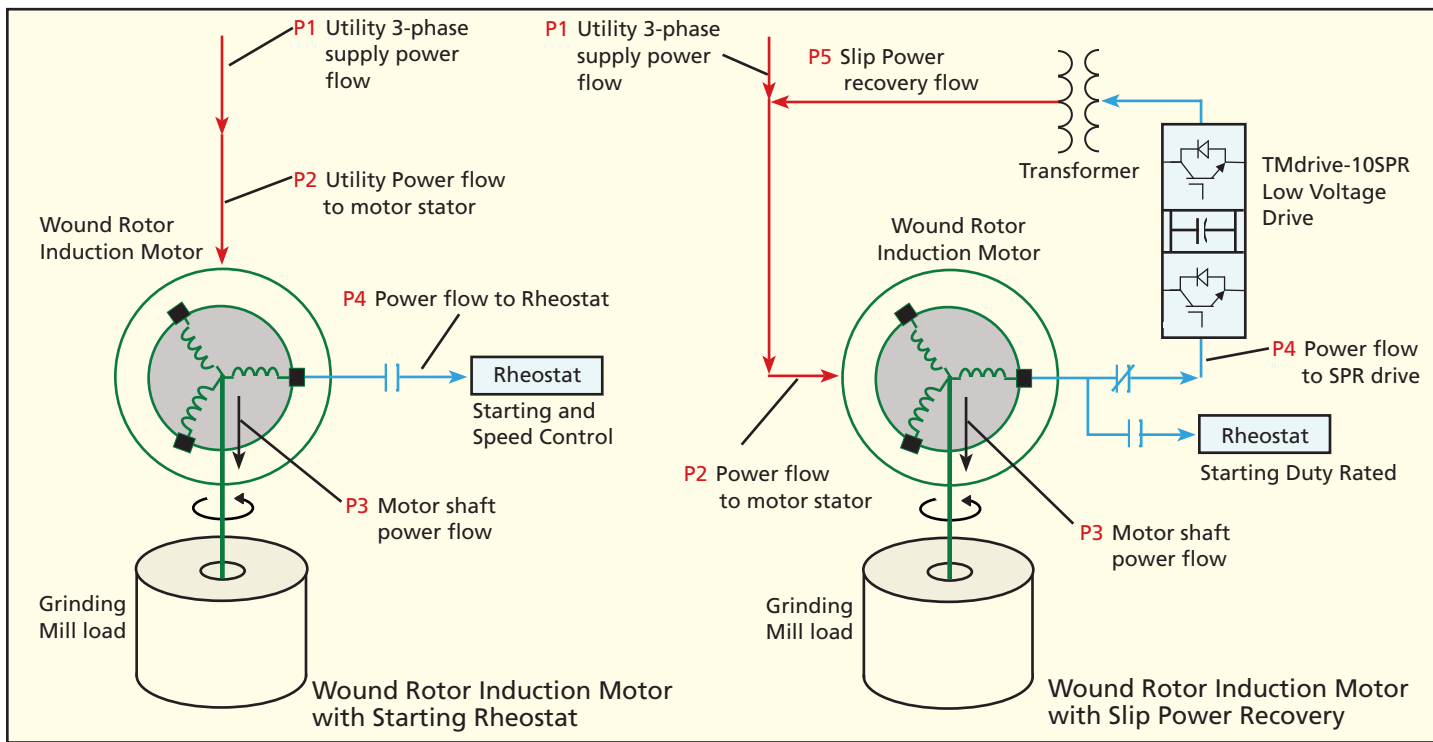

Comparison of Wound Rotor Induction Motor Control Systems

Calculations for the energy savings with the SPR drive are shown below. Note that the slip power varies with the slip speed (synchronous speed minus the actual motor speed).

Calculation of Savings with Slip Power Recovery Drive

Energy Efficiency	Basic Equations		
Energy efficiency of the components are estimated as follows: <ul style="list-style-type: none"> • SPR drive efficiency = 0.97 • Transformer efficiency = 0.99 • Motor efficiency = 0.95 • Slip power from the rotor (est.), P4: Full Load x Slip % = 373 kW 	For the slip power recovery case above, the basic energy flow equations are: <ul style="list-style-type: none"> • $P1 = \text{Motor Power} - \text{Recovered Power} = P2 - P5$ where • $P2 = P3 + \text{Motor Losses} + \text{Rotor Power} = P3 / (\text{Motor Efficiency}) + P4$ • $P5 = P4 \times \text{Drive Efficiency} \times \text{Transformer Efficiency}$ 		
Operating Conditions	Power Flow	Wound Rotor Motor (WRM) with Rheostat	WRM with Slip Power Recovery Drive
Mill Load at Full Speed, shaft kW	–	3730 kW (5,000 hp)	3730 kW (5,000 hp)
Mill load at 90% speed, shaft kW	P3	3357 kW (assume linear)	3357 kW
Power flow from Slip Rings (est.)	P4	373 kW (to rheostat)	373 kW (to SPR drive)
Power flow to motor (95) efficient)	P2	3906 kW	3906 kW
Slip power recovery after transformer	P5	0 kW	358 kW
Utility supply power flow	P1	3906 kW	3548 kW
Difference in utility power used P1(WRM) - P1(SCR)		358 kW	
SPR System Annual Savings with 7¢ electrical power		\$200,480 per year (8000 hours)	

Application 3. Transporting Ore by Conveyor - Tough Speed and Torque Control

A train transporting ore to a processing plant had become obsolete and unreliable. TMEIC's solution was to replace the train with a conveyor to transport the ore. The conveyor was segmented into three pieces: Conveyor 1 lifts the ore to the surface, Conveyor 2 moves the ore several miles, and Conveyor 3 moves the ore to the processing plant. The longest segment, Conveyor 2, is detailed below.



Typical overland conveyor

The Longest Conveyor Segment

Four large drives and induction motors totaling 9,000 hp move the longest conveyor segment. High altitude required drive derating and attention to cooling. As shown below, the grade varies from 1% up to 5%.

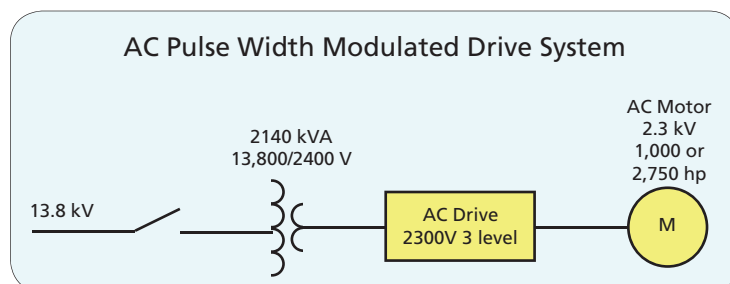
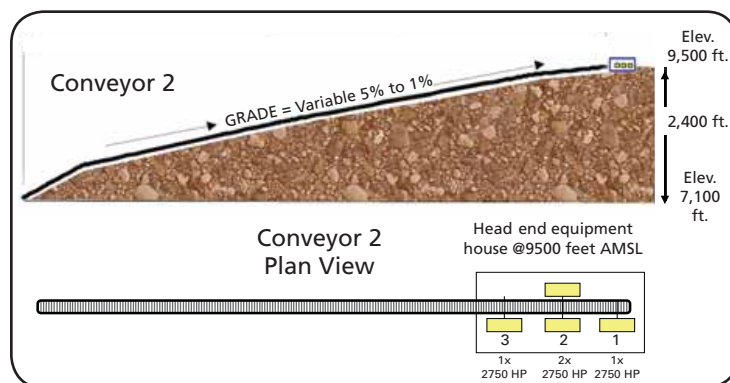

Conveyor 2 Design Challenges

Motor Challenges: The system required:

- Motor powers up to 2250 hp with high starting torque
- Wide speed range

Motor Solution: 2.3 kV induction motors with separate cooling air system supplied by the user.

Drive Challenges: The drives must be:

- Reliable for continuous service
- Energy efficient
- Low maintenance

Drive Solution: TMEIC ac drives for 2300 volt operation, with 3-level PWM inverters and 18-pulse rectifiers.

Control Challenges: The system required:

- Precise torque for belt tension control
- Head to tail tension coordination
- Variable speed operation of any motor.

Control Solution: An Innovation Series controller for torque programming.

Power Challenges: The system required long power feeds, and needed to avoid capacitance-created resonance at high order harmonics.

Power Solution: The power system employs:

- 3-level inverters with IEEE 519 compliant, 18-pulse converters
- High frequency filters to eliminate cable resonance at 19th harmonic

Benefits of ac Drive System



Very reliable system. Replacing the train with the conveyor and variable frequency drive system resulted in:

- High reliability
- Reduction in maintenance & down time



Variable speed brings benefits. Conveyor speed control resulted in several benefits:

- Energy savings
- Reduced friction
- Reduced belt wear



Technical risks avoided. Careful design avoided failure potentials such as slippage and stretch of the miles-long total belt length driven by 9,000 hp at the head end (four motors of 2,250 hp each).

The Medium Voltage VFD System

TMEiC application engineers consider the system from the medium voltage switchgear to the adjustable speed drive and motor, sizing and selecting required equipment for the optimal drive solution. A typical MV VFD system is shown below.



- Instrumentation** for equipment metering, monitoring, protection and control is selected:
- Amp transducer and ammeter
 - Watt and Watt-hr transducers
 - Phase CTs and phase overcurrent relay
 - Ground sensor CT and relay
 - Power quality monitor



- Selection of optional drive associated equipment**
- Heat exchangers if required
 - Air conditioned equipment house if required
 - Switchgear if motor is to be synchronized with the line
 - PLC for logic control
 - Reactor for use with an LCI



- Selection of the motor**
- Induction, synchronous, wound rotor or dc motor
 - Motor specs including power, torque, voltage, current, and speed
 - Selection of exciter for sync motor
 - Required motor protection devices
 - Optional tachometer
 - Optional Torsional analysis

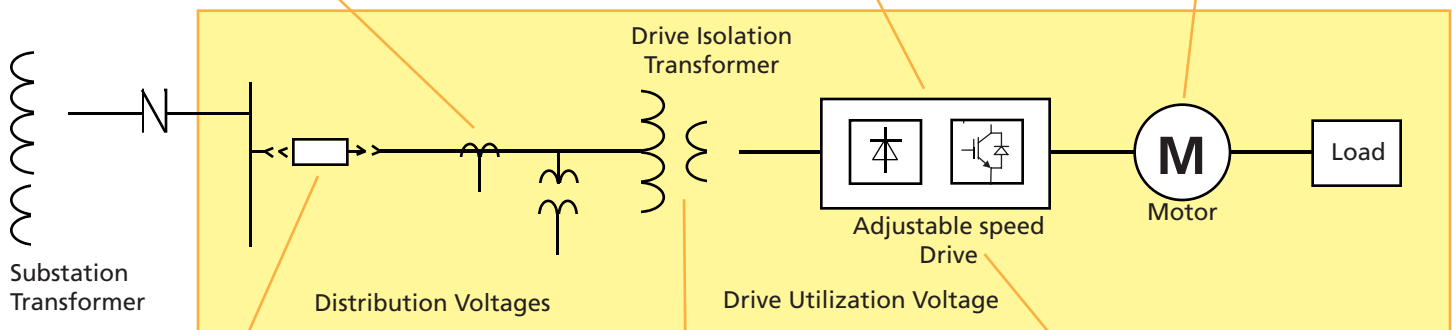

- MV Switchgear** is selected for the application considering:
- The type, such as vacuum or SF6
 - The size for the current and voltage
 - The CTs, PTs, and protective relays to operate the breaker
 - The enclosure for outdoor or indoor
 - The environment, such as temperature and humidity



- Drive Isolation transformers, input and output**, are selected for the application considering:
- The type, such as dry or liquid filled
 - Size for the kVA and voltage
 - Cooling, if required
 - The enclosure for outdoor or indoor
 - The environment, such as temperature and humidity



- Selection of the best adjustable speed drive** for the application:
- Continuous and overload torque and power requirements
 - Type of load, including constant or variable torque, regenerative
 - Drive and motor voltage
 - Power system compatibility
 - Overall efficiency of the ASD and motor combination
 - Harmonic analysis

Project Engineering



General Industries Team

Experienced Drive Engineering Team

The drive engineering team's experience in the mining industry was gained through years of working in mines with technicians and mechanical suppliers. This engineering background, coupled with state-of-the-art technology, enables TMEIC to consistently meet the very demanding requirements of the industry.

Experienced drive engineers jointly define the drive equipment and control strategy with your engineers and the OEM. This is followed by detailed design of the system, control logic, and configuration of the drives.

Local Commissioning Team Ensures Knowledgeable Ongoing Service

Our globally-based field organization has extensive experience in the industry providing you with a strong service presence for startup and ongoing service work.

Project Life Cycle Process Minimizes Risk

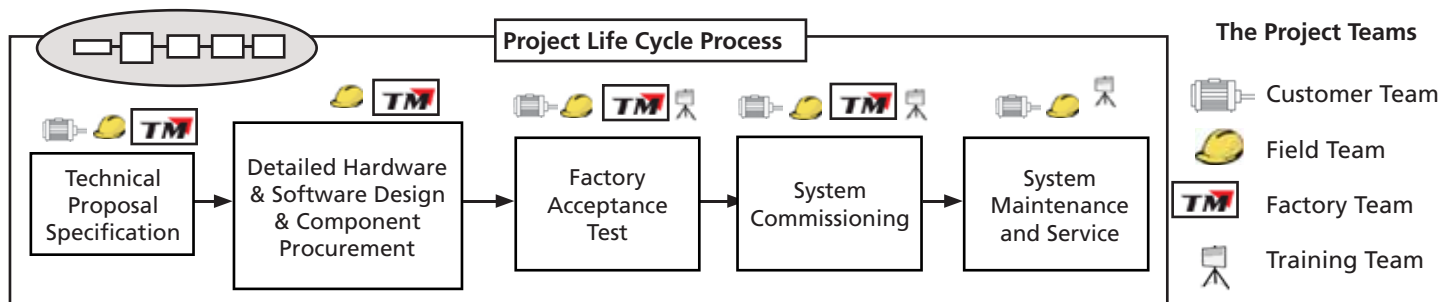

We understand that delay in your equipment commissioning is very expensive, so we take steps to hold our startup schedule. Our project engineering is based on the Project Life Cycle Process illustrated above and described in the following pages.

- Project management provides a single point of contact from initial order to final commissioning.

- Complete factory tests are conducted including applying power to the drive bridges and exercising the control system using motor and load simulators.
- The local commissioning engineers are included in the project team, allowing a seamless transition from the factory to your mine.

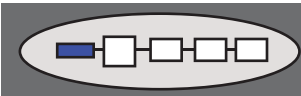

Project Planning and Specification

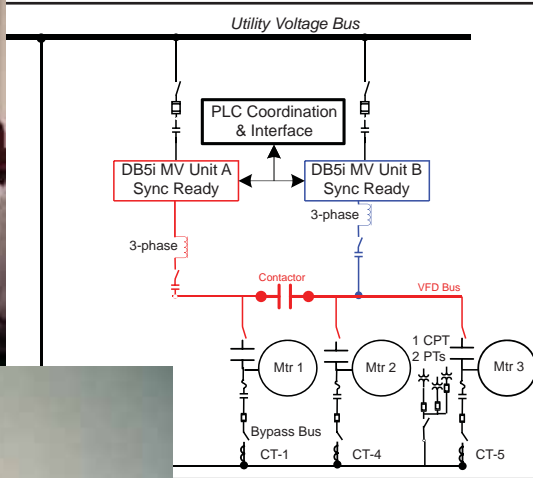

During all phases of your project planning, TMEiC assists you by supplying information, training, guide-form specifications, and general advice. Experienced drive application engineers prepare a technical proposal that includes:

- Customized system architecture for your project.
- Detailed equipment specifications for the drives, motors, excitors, transformers, switchgear, and housings.
- Thorough description of the PLC and other control functions.
- Formal bid documentation.

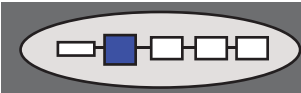

Detailed Hardware/Software Design and Procurement

Based on the proposal specification, the project engineering team proceeds with four main tasks:

- **Control Software Design.** Control engineers configure the drives and PLC controller logic, if a PLC is required for the application. The illustration shows a typical toolbox logic function diagram in Relay Ladder Diagram format. The software tool is used for drive configuration, tuning, sequencing, and drive diagnostics.
- **Optional HMI Screen Design.** Interface screens for maintenance and drive control can be configured. For example, the configurable keypad shown here provides real-time drive data and operator interaction.
- **Hardware Design.** All equipment is specified to meet the project requirements, and a complete set of elementary diagrams, layout, and outline drawings is created.
- **Component Procurement.** We work with our parent and partner suppliers to source the most cost effective system components for your application.

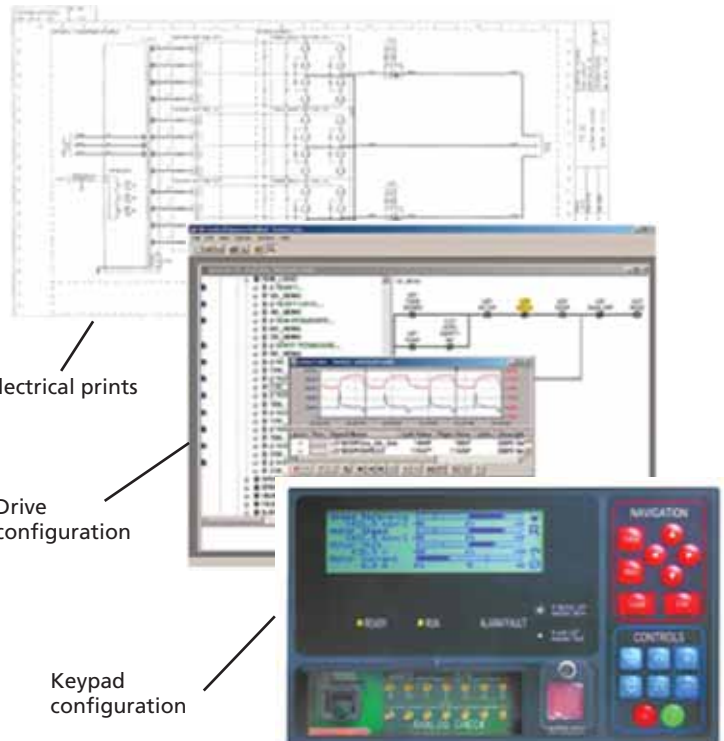

Drive and System Test

Understanding the importance of a thorough drive and system test, the TMEIC engineering team conducts factory tests before shipment. Drive tests in the factory typically include:

- Full voltage and current check of power cells, insulation, and control circuits.
- Acceleration and run test with unloaded motor.
- Full current test into a reactor (ac drives).
- Validation of all I/O interfaces.
- Validation of the drive test modes and any special logic, or optional PLC using motor and load simulator.



Dura-Bilt5i MV Drive Testing

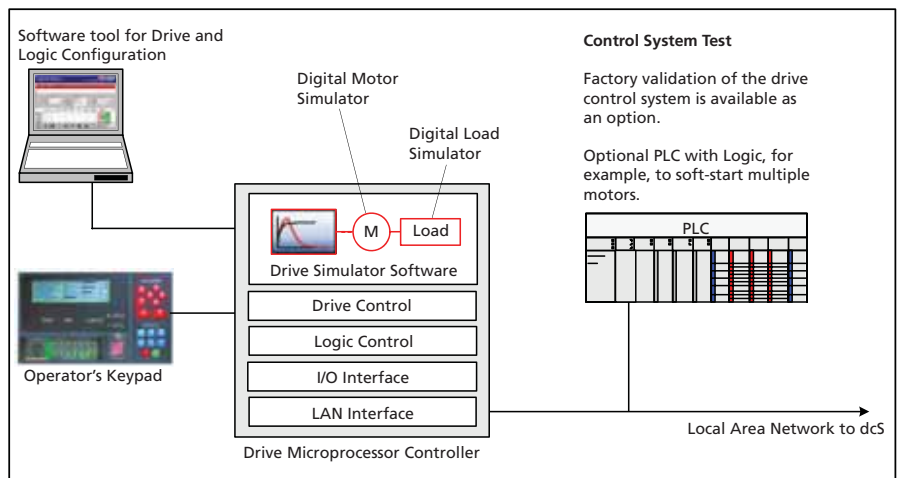

System Commissioning

In the commissioning phase, the TMEIC team includes the field engineers you know and trust, alongside the engineer who designed and tested the system. This overlap of teams between engineering design and the site ensures a smooth and on-schedule startup.

The TMEIC service engineer, who is responsible for startup and commissioning, and for any future service required at the site, is part of the project team and participates in the factory system test to become familiar with the system. Commissioning is supported by TMEIC design and service engineers.

Complete & Detailed System Documentation

Along with the hardware and software, TMEIC delivers complete system documentation:

- An electronic instruction book with all the prints on CD with a hyperlink index;
- Recommended wiring and grounding procedures;
- Renewal parts list; and
- Standard third-party vendor documentation.
- Validation of the drive test modes and any special logic, or optional PLC using motor & load simulator.



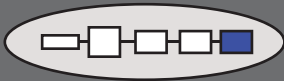

Global Customer Support Network

Comprehensive technical service is provided by our Customer Support Organization, staffed by TMEiC service engineers with offices and spare parts depots across the globe.

In North and South America

Customers are supported by the TMEiC Corporation service personnel, design engineers and Spare Parts Depot in Virginia, and the TMEiC Factory in Japan.

In Europe

TMEiC service engineers service all drive systems in Europe, supported by the European TMEiC Spare Parts Depot.

In Asia and the Pacific Rim

TMEiC services drive systems throughout China, India and the Pacific Rim, supported by multiple Field Engineers, Spare Parts Depots, and the TMEiC factory in Japan.

Remote Drive Diagnostics

TMEiC Corporation supports drive customers through the **Remote Connectivity Module (RCM)**, a remote diagnostic service link with the TMEiC design and service engineers in Roanoke, Virginia. The RCM enables seamless integration between your drives and our engineers.

Remote System Diagnostics

TMEiC's remote system diagnostics tool, included in level 1 software, offers a quick path to problem resolution. System faults are automatically identified, and provide an integrated view of product, process and system information. TMEiC design and service engineers in Roanoke, Virginia, can analyze the data and provide steps for resolution.



TMEiC

For Service or Parts, call
1-877-280-1835

INTERNATIONAL:
+1-540-283-2010
24 Hours / 7 days

Drive Training at our Training Center or in Your Facility



Customer engineers, maintenance and operations personnel are trained on the drives and control system at the TMEiC Training Center in Virginia. This world-class facility features large classrooms and fully-equipped training labs.

Classroom and hands-on training consists of 50% class time and 50% hands-on lab time. Topics include:

- Overview of the drive system
- Function of the main assemblies
- Technical details of the components
- Drive and control system tools
- System diagnostics and service

As an alternative to the standard factory training in Virginia, TMEiC can offer a course tailored to your project and held at your location. In this case, a project engineer trains your operators, maintenance technicians and engineers in your facility.

A Family of Drives up to 11 kV

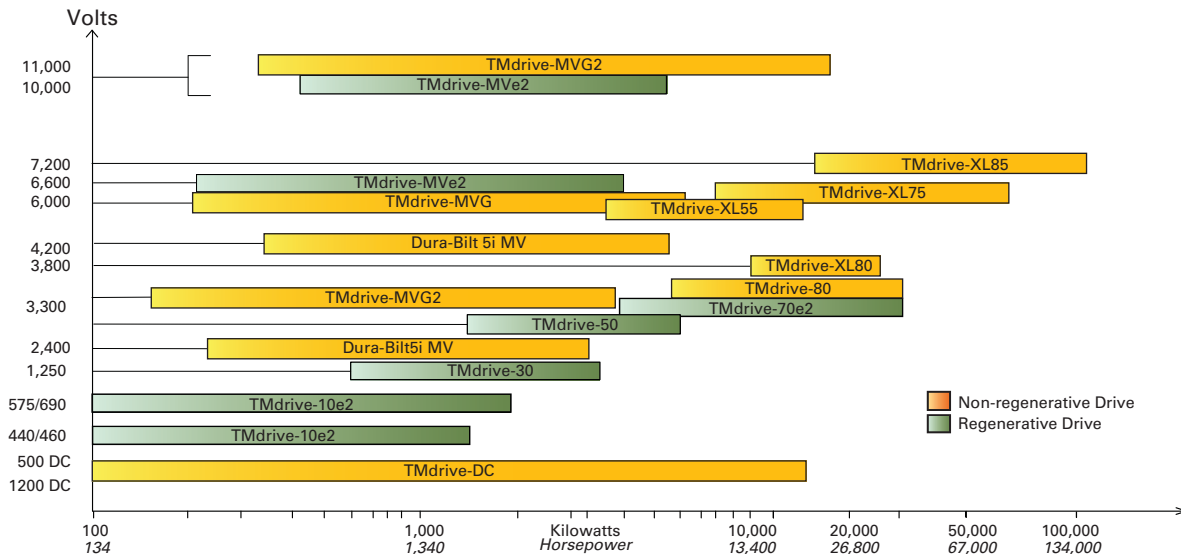

AC drive Voltages up to 11 kV. The family of ac drives offers voltages from 380 V up to 11kV. The dc drive family covers 230 to 1200 vdc

Significant Investment in Drive Technology. TMEIC’s Dura-Bilt and TMdrive products represent a large investment in LV and MV drive technology, including development of semiconductor devices such as the IEGT and GCT.

The Highest Reliability. TMEIC drives provide the highest reliability based on field experience and customer satisfaction survey results.

Configuration Software. The TMdrive Navigator world-class configuration software is used on all TMEIC drives. Live block diagrams and tune-up wizards streamline commissioning and maintenance activities.

Spare Parts Stock. TMEIC’s parts depots stock the line of LV and MV drive parts to provide rapid delivery to your facility anywhere in the world.

TMdrive-Navigator Software

The MVe2 keypad, coupled with the Windows® based TMdrive Navigator brings productivity to your commissioning and maintenance activities.

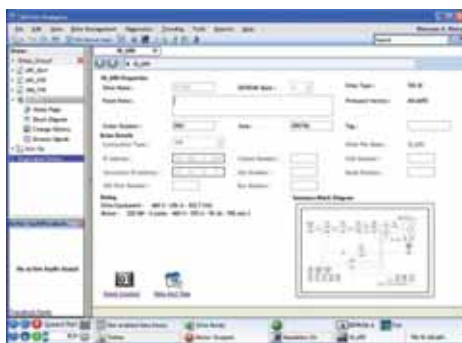

The Navigator tool helps maintain TMEIC drives in the field. Any user can easily access current drive expertise & know-how. Compatible with OS Windows 7 and Professional 32-bit

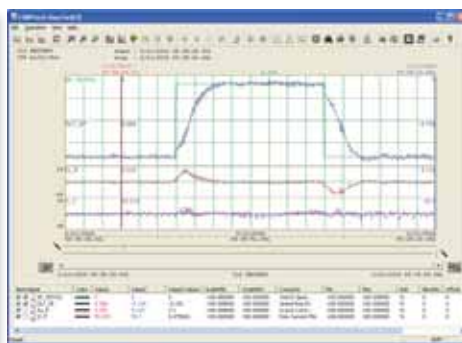

High speed data is automatically captured and saved in the event of a drive fault. Users can capture high speed data based on their own trigger conditions or perform high resolution real-time trending.

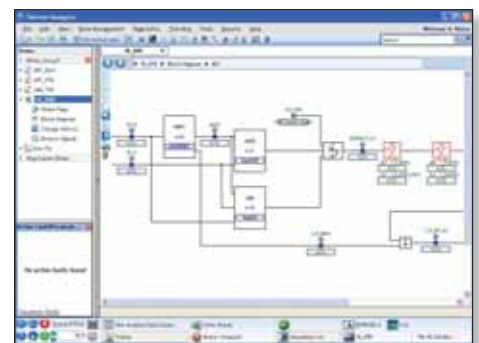

Live block diagrams provide a real-time graphical view of drive functions. Functions can be configured directly from the graphical view.

Product documentation is integrated into tool. Users can capture their own notes to benefit future troubleshooting.

Medium Voltage Motor and Drives Systems School

TMEIC Corporation is pleased to offer its tuition-free MV Motor and Drives Systems School to its customers. These schools are offered regularly in Roanoke, Virginia, and other cities.



Course Topics:

- Medium Voltage (MV) induction and synchronous motors
- Fundamentals of variable frequency drives
- MV drive characteristics, payback, and specifications
- MV power systems design concepts
- MV switchgear, starters, transformers, reactors, and substations
- MV system protection
- Real-world industrial application stories from the mining, cement, oil & gas, petrochemical and water & waste water industries
- Equipment demonstrations

For details and registration for our next school, please visit our Web site at www.tmeic.com.

Global Office Locations:

TMEIC Corporation

Office: 1325 Electric Rd., Roanoke, VA, 24018, U.S.A.
Mailing: 2060 Cook Drive, Salem, VA, 24153, U.S.A.
Tel.: +1-540-283-2000; Fax: +1-540-283-2001
Email: info@tmeic.com; Web: www.tmeic.com

Houston Branch: Houston, TX;
Tel: +1-832-767-2680; Email: OilGas@tmeic.com

TMEIC Power Electronics Products Corporation

Factory: 6102 North Eldridge Parkway, Houston, TX 77041
Mailing: 13131 W. Little York Road, Houston, TX 77041

TMEIC-Sistemas Industriais da América do Sul Ltda.

São Paulo/SP, Brazil
Tel: +55-11-3266-6161; Fax: +55-11-3253-0697

Toshiba Mitsubishi-Electric Industrial Systems Corp.

Tokyo, Japan; Tel: +81-3-3277-5511; Web: www.tmeic.co.jp

TMEIC Europe Limited

Uxbridge, Middlesex, United Kingdom
Tel.: +44 870 950 7220; Fax: +44 870 950 7221
Email: info@tmeic.eu; Web: www.tmeic.com/europe

TMEIC Industrial Systems India Private Limited

Hyderabad, India;
Tel.: +91-40-4434-0000; Fax: +91-40-4434-0034
Web: www.tmeic.in; Email: inquiry_india@tmeic.in
Mumbai Branch: Mumbai, Maharashtra, India
Tel: +91-22-6155-5444; Fax: +91-22-6155-5400

TMEIC Power Electronics Systems India Private Ltd.

Bangalore, India,
Tel: +91-80-6746-6000; Fax: +91-80-6746-6100

Toshiba Mitsubishi-Electric Industrial Systems (China) Corp.

Beijing China; Tel.: +86 10 5873-2277; Fax: +86 10 5873-2208
Email: sales@tmeic-cn.com

Shanghai Branch: Shanghai Works

Tel: +86-21-69925007; Fax: +86-21-69925065

Yangcheng TMEIC Power Electronics Corporation

Yangcheng, Jiangxi, China

Shanghai Bao-ling Electric Control Equipment Co., Ltd.

Shanghai, China; Tel: +86-21-5660-3659; Fax: +86-21-5678-6668

Guangzhou Toshiba Baiyun Ryoki Power Electronics Co., Ltd.

Guangzhou, China; Tel: +86-20-2626-1625 Fax: +86-20-2626-1290

TMEIC Asia Company Limited

Hong Kong, China; Tel: +852-2243-3221; Fax: +852-2795-2250

Singapore Branch: Tel: +65-6292-7226 FAX: +65-6292-0817

Taiwan Office: Tel: +886-7-2239425 Fax: +886-7-2239122

P.T. TMEIC Asia Indonesia

Jakarta; Tel: +62-21-2966-1699; Fax: +62-21-2966-1689

TMdrive is a registered trademark of TOSHIBA MITSUBISHI-ELECTRIC INDUSTRIAL SYSTEMS CORPORATION.

All other products mentioned are registered trademarks and/or trademarks of the respective companies.

All specifications in this document are subject to change without notice. This brochure is provided free of charge and without obligation to the reader or to TMEIC Corporation, and is for informal purposes only. TMEIC Corporation does not accept, nor imply, the acceptance of any liability with regard to the use of the information provided. TMEIC Corporation provides the information included herein as is and without warranty of any kind, express or implied, including but not limited to any implied statutory warranty of merchantability or fitness for particular purposes. The brochure is not an implied or express contract.

If you have questions regarding your project requirements, please contact TMEIC Corporation at 540-283-2000.